

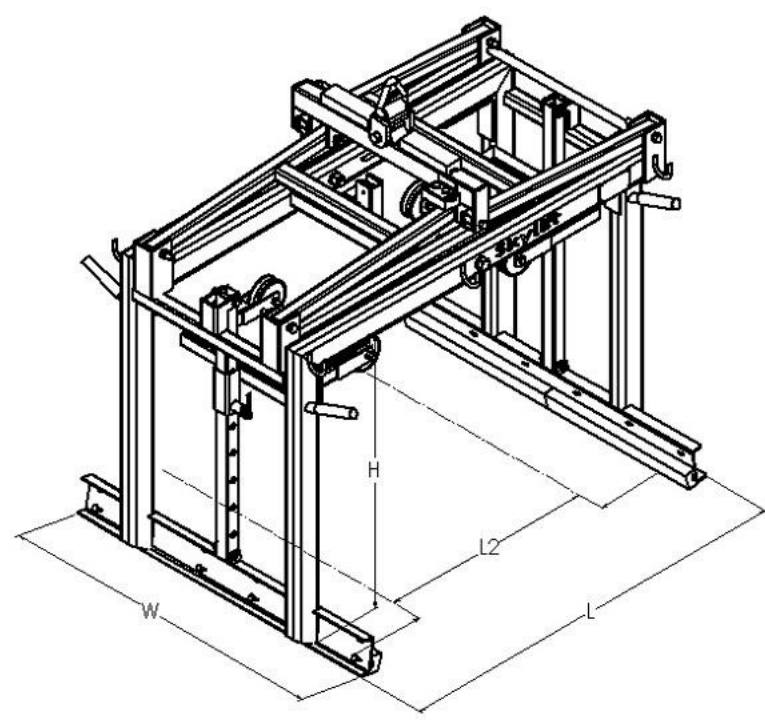

Block Grab

Skylift Mechanical Block Grab used to handle Blocks and Bricks within the site using crane as it can be used with forklifts or any equipment with fork attachment when its mounted with the extra fork add-on. The Well-made Block Grab constructed with high-quality materials. The automatic lock mechanism enables a single operator to stack or unstack loads. The Fork Attachment is optional as we highly recommend to use it with Safety Net. **Skylift** Block Grab designed and manufactured according to the **UNI EN ISO 12100-1**, **UNI EN 10204**, **UNI ISO 8686-1** international standards.



OUR LIFTING PRODUCTS
CERTIFIED BY



MODEL	CAP. (Kg)	DIMENSIONS (mm)				WEIGHT (Kg)
		W	H	L	L2	
SKL 18-85	1800	1200	850	1100	400	250
SKL 18-100	1800	1200	1000	1350	800	300

www.skylift-me.com

