

Material Lifting Cage

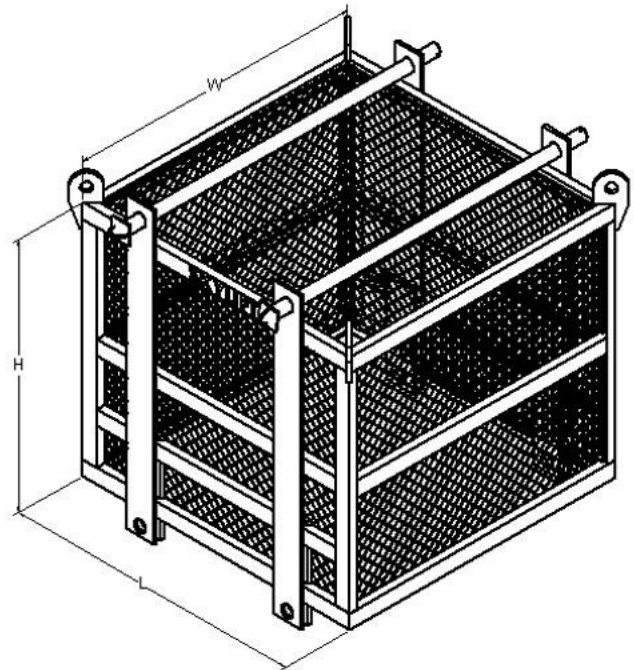

Skylift Material Lifting Cage. Designed to handle materials such as Blocks, Cement Bags, Tiles or any palletized Materials safely to a desired location within the building by tower crane. The Sturdy Cage constructed with mesh sides & high-quality materials. Skylift designed and manufactured according to the **UNI EN 13155, UNI EN ISO 12100, UNI EN 349, UNI ISO 8686** and **UNI EN 10204** international standards.

**OUR LIFTING
PRODUCTS**
CERTIFIED BY



MODEL	CAPACITY (Kg)	WEIGHT (Kg)			Weight (kg)
		L	W	H	
SKL 150 BC	2000	1490	1490	1610	250